

# TOGGLE CLAMPS

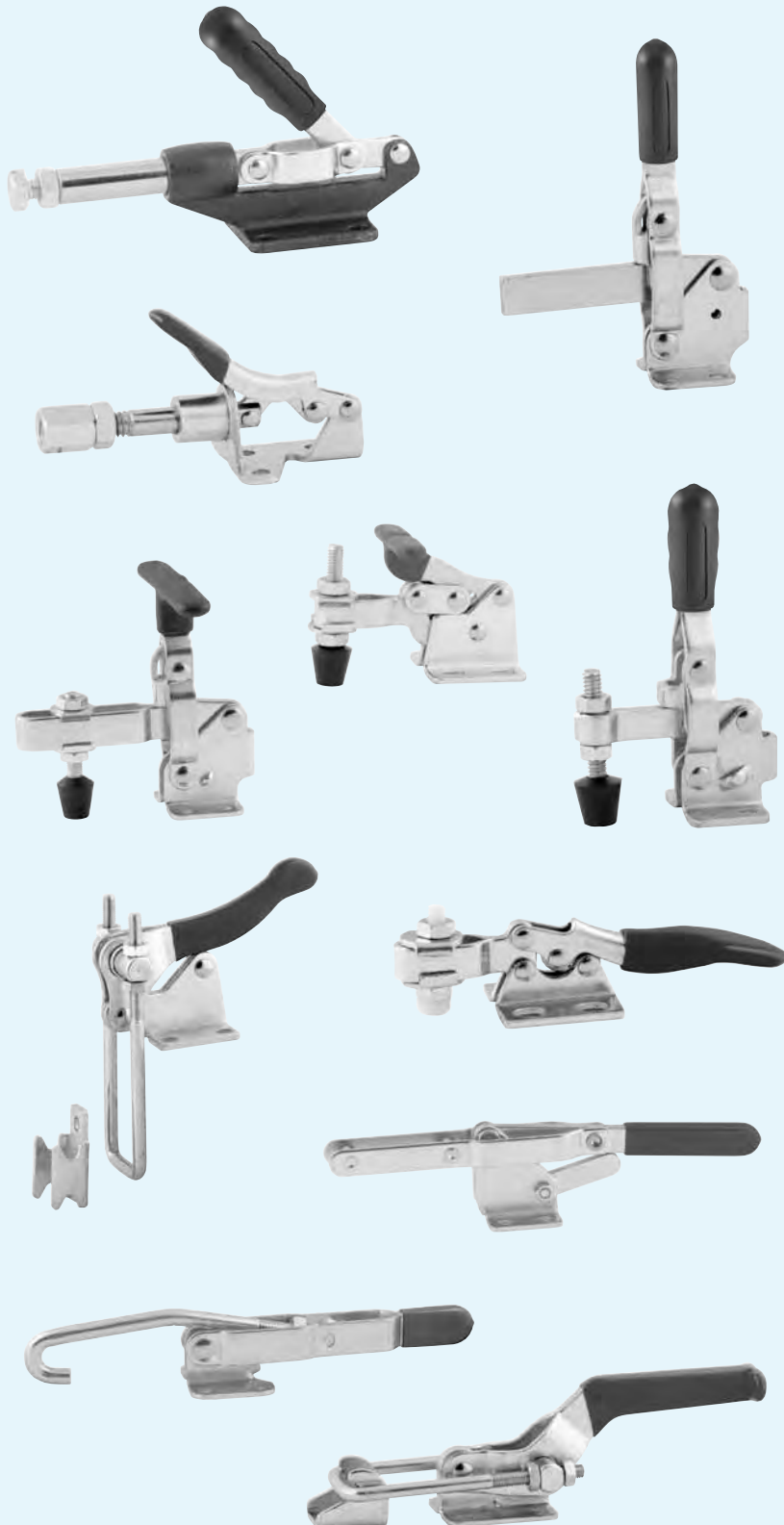

Vertical Handle ..... 128-130

Horizontal Handle..... 131-132

Straight Line Action ..... 133-135

Pull Action ..... 136-138

Accessories ..... 138

## General Information

### HOLDING CAPACITY

The **holding capacity** listed for each clamp refers to the maximum external force that the clamp can safely resist in its locked position without incurring any permanent deformation. For hold down clamps, holding capacity is measured with the spindle as close as possible to the handle, and will be less at the end of the clamping arm.

### CLAMPING FORCE

**Clamping force**, the amount of force actually applied to the workpiece by closing and locking the clamp, is generally less than the stated holding capacity. This allows the clamp to have ample capacity to resist external machining forces. Actual clamping force depends on many factors including: spindle position, proper spindle height adjustment, type of spindle used, workpiece material, and the clamp's mechanical advantage. In most cases roughly 1/2 of the stated holding capacity can be applied by hand with medium effort.

## Vertical Handle Toggle Clamps

- One of the most popular styles of Toggle Clamps
- Solid bar allows fixed location of spindle by welding bolt retainer at desired position
- U-Bar allows spindle to be located anywhere on bar length
- Flanged bases provide optimum holding pressure
- T-Handles provide greater clearance for machines
- All clamps include spindle assembly

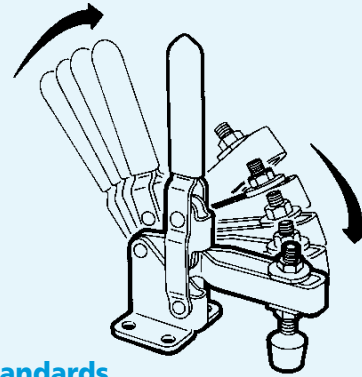

All TE-CO Toggle Clamps are interchangeable with industry standards

## Vertical Handle Toggle Clamps Part Numbers 34001 and 34003

Bar Opens: 100°  
Handle Opens: 56°  
Spindle Type: Bonded Neoprene  
Spindle Size: #10-24 X 1.38

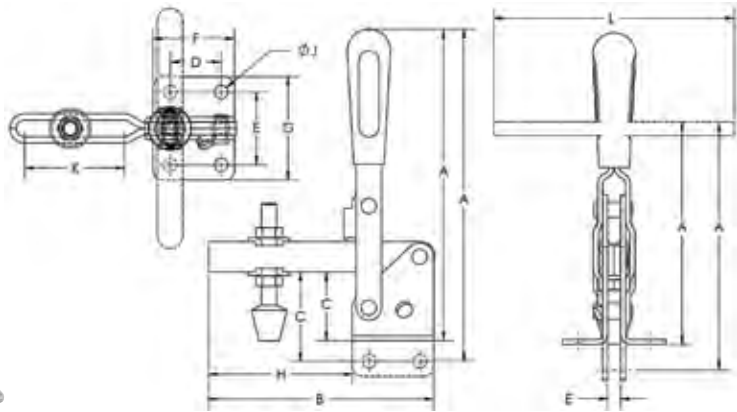

Part No.	A	B	C	D	E	F	G	H	J	K	L	Bar Type	Base Type	Holding Cap. Lbs.	Handle Type
34001	3.38	2.07	0.73	0.63	0.95	1.00	1.32	1.06	0.17	0.77	-	ADJUSTABLE	FLANGED	100	STANDARD
34003	2.41	2.07	0.68	0.63	0.94	1.00	1.32	1.06	0.17	0.81	1.77	ADJUSTABLE	FLANGED	100	T-HANDLE

## Vertical Handle Toggle Clamps Part Numbers 34010, 34006, 34008, 34012

Bar Opens: 100°  
Handle Opens: 60°  
Spindle Type:  
Bonded Neoprene  
Spindle Size: 1/4-20 X 1.75

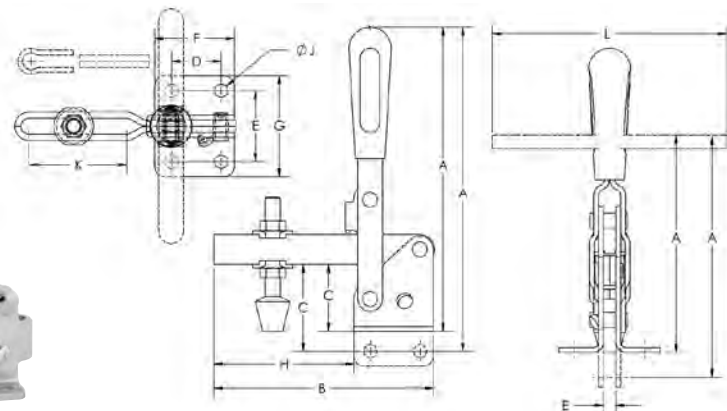

Part No.	A	B	C	D	E	F	G	H	J	K	L	Bar Type	Base Type	Holding Cap. Lbs.	Handle Type
34010	4.01	2.50	0.98	0.51	1.00	0.98	1.50	1.28	0.21	-	-	SOLID	FLANGED	200	STANDARD
34006	4.01	2.68	0.95	0.52	1.03	0.98	1.50	1.68	0.20	1.08	-	ADJUSTABLE	FLANGED	200	STANDARD
34008	3.12	2.68	0.98	0.51	1.03	0.98	1.53	1.70	0.20	0.98	-	ADJUSTABLE	FLANGED	200	T-HANDLE
34012	3.03	2.50	0.97	0.56	0.99	0.99	1.48	1.26	0.21	-	2.60	SOLID	FLANGED	200	T-HANDLE

## Vertical Handle Toggle Clamps

Part Numbers 34023, 34020, 34022, 34025, 34009

Bar Opens: 100°

Handle Opens: 60°

Spindle Type: Bonded Neoprene

Spindle Size: 5/16-18 X 2.50

PART #34020



PART #34023



PART #34022



PART #34025

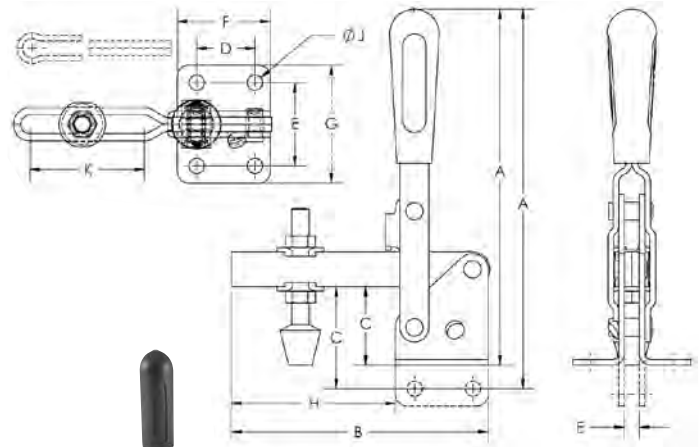

Part No.	A	B	C	D	E	F	G	H	J	K	L	Bar Type	Base Type	Holding Cap. Lbs.	Handle Type
34023	5.60	5.43	1.25	0.78	1.25	1.38	1.77	3.75	0.27	2.79	-	LONG ADJUSTABLE	FLANGED	500	STANDARD
34020	5.88	4.59	1.23	0.75	1.25	1.38	1.82	2.85	0.27	2.05	-	ADJUSTABLE	FLANGED	200	STANDARD
34022	4.10	4.60	1.23	0.75	1.25	1.38	1.77	2.86	0.27	2.10	3.86	ADJUSTABLE	FLANGED	375	T-HANDLE
34025	5.90	3.75	1.26	0.74	1.25	1.37	1.80	2.24	0.27	-	-	SOLID	FLANGED	375	STANDARD
34009	5.58	4.78	1.26	0.75	1.25	1.38	1.76	3.40	0.27	-	-	LONG SOLID	FLANGED	500	STANDARD

## Vertical Handle Toggle Clamps

Part Numbers 34030, 34015, 34035

Bar Opens: 105°

Handle Opens: 58°

Spindle Type: Bonded Neoprene

Spindle Size: 3/8-16 X 3.50

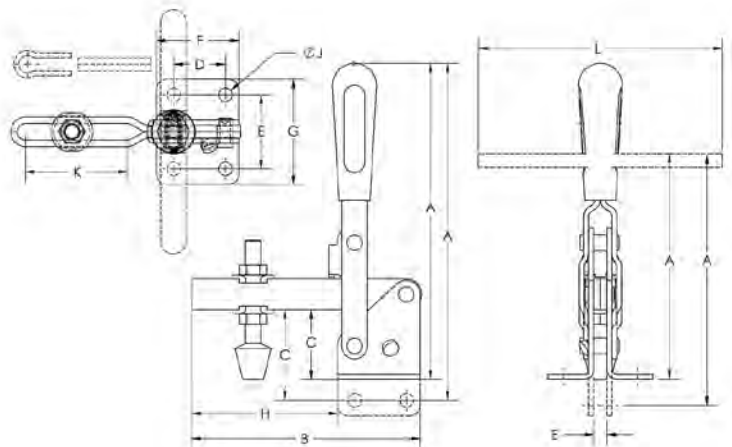

Part No.	A	B	C	D	E	F	G	H	J	K	L	Bar Type	Base Type	Holding Cap. Lbs.	Handle Type
34030	7.96	5.65	1.66	1.25	1.80	1.94	2.55	3.56	0.31	2.31	-	ADJUSTABLE	FLANGED	600	STANDARD
34015	5.60	5.50	1.62	1.25	1.77	1.94	2.50	3.56	0.31	2.40	5.13	ADJUSTABLE	FLANGED	600	T-HANDLE
34035	7.89	5.59	1.26	1.25	1.81	1.94	2.56	3.53	0.31	-	-	SOLID	FLANGED	750	STANDARD

# TOGGLE CLAMPS



## Vertical Handle Toggle Clamps Part Numbers 34040, 34041

Bar Opens: 135°  
Handle Opens: 70°  
Spindle Type: Hex Head  
Spindle Size: 1/2-13 X 3.00

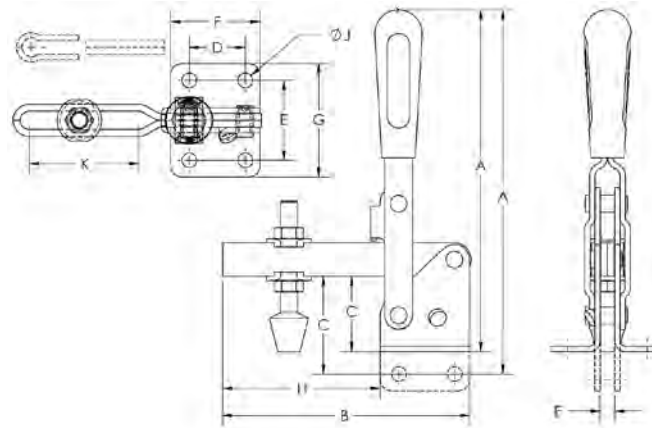

Part No.	A	B	C	D	E	F	G	H	J	K	L	Bar Type	Base Type	Holding Cap. Lbs.	Handle Type
34040	8.81	6.89	1.95	1.25	1.77	2.00	2.56	4.87	0.35	2.98	-	ADJUSTABLE	FLANGED	1000	STANDARD
34041	8.81	7.12	2.00	1.26	1.78	2.01	2.56	4.95	0.35	-	-	SOLID	FLANGED	1000	STANDARD

## Vertical Handle Toggle Clamps Part Numbers 34050, 34029

Bar Opens: 140°  
Handle Opens: 60°  
Spindle Type: Hex Head  
Spindle Size: 1/2-13 X 4.50

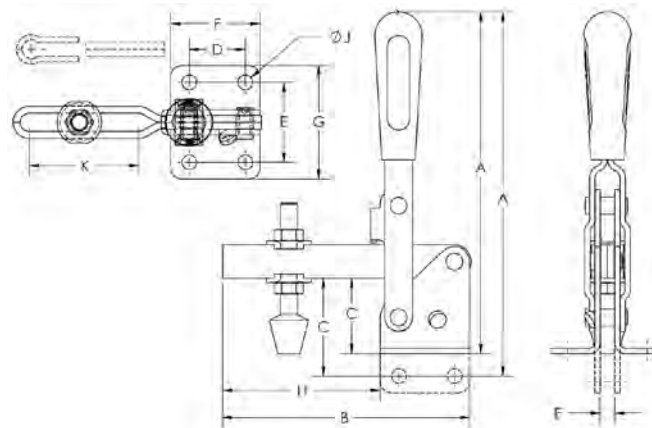

Part No.	A	B	C	D	E	F	G	H	J	K	L	Bar Type	Base Type	Holding Cap. Lbs.	Handle Type
34050	11.87	9.00	3.08	2.00	2.75	2.99	3.75	5.99	0.48	4.33	-	ADJUSTABLE	FLANGED	1200	STANDARD
34029	11.83	8.97	3.22	2.00	2.75	2.99	3.75	5.98	0.48	-	-	SOLID	FLANGED	1200	STANDARD

## Horizontal Handle Toggle Clamps

- U-Bar allows the spindle to be located anywhere on bar length
- All clamps supplied with spindle assembly
- Handles stay clear of the workpiece while machining
- Flanged bases provide optimum holding pressure

All TE-CO Toggle Clamps are interchangeable with industry standards

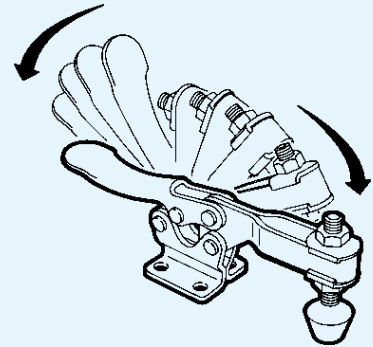

## Horizontal Handle Toggle Clamps Part Numbers 34105, 34101



Bar Opens: 90°  
Handle Opens: 80°  
Spindle Type: Nylon Hex Head  
Spindle Size: #8-32 X .75

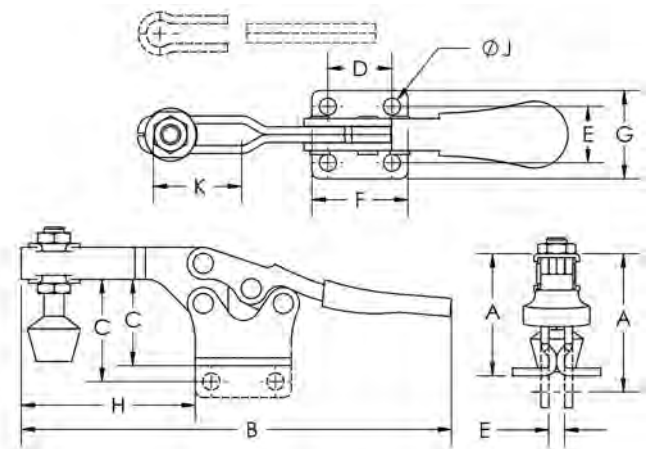

Part No.	A	B	C	D	E	F	G	H	J	K	L	Bar Type	Base Type	Holding Cap. Lbs.	Handle Type
34105	0.70	3.10	0.34	0.42	0.65	0.95	0.98	0.78	0.17	0.48	-	ADJUSTABLE	FLANGED	60	STANDARD
34101	0.73	3.24	0.42	0.41	0.64	0.95	0.99	0.87	0.17	-	-	SOLID BAR	FLANGED	60	STANDARD

## Horizontal Handle Toggle Clamps Part Number 34107



Bar Opens: 85°  
Handle Opens: 60°  
Spindle Type: Bonded Neoprene  
Spindle Size: 1/4-20 X 2.13

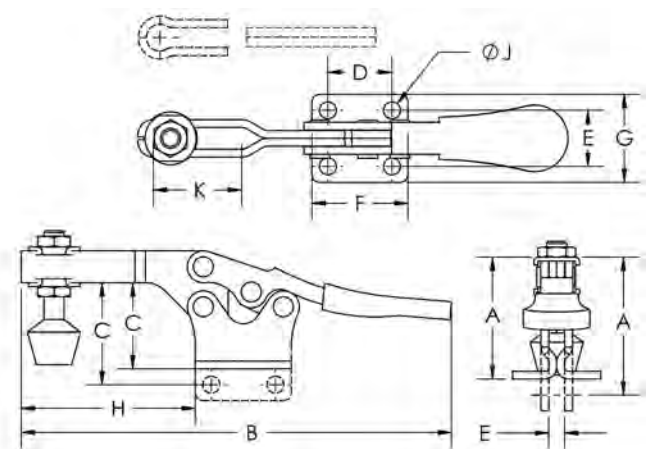

Part No.	A	B	C	D	E	F	G	H	J	K	L	Bar Type	Base Type	Holding Cap. Lbs.	Handle Type
34107	1.53	5.90	1.00	0.98	0.83	1.46	1.34	2.27	0.21	-	-	SOLID BAR	FLANGED	200	STANDARD

# TOGGLE CLAMPS



## Horizontal Handle Toggle Clamps Part Numbers 34113, 34114, 34115

Bar Opens: 90°  
Handle Opens: 170°  
Spindle Type: Bonded Neoprene  
Spindle Size:  
• #10-24 X 1.38 (34113)  
• 5/16-18 X 2.50 (34114)  
• 3/8-16 X 3.50 (34115)

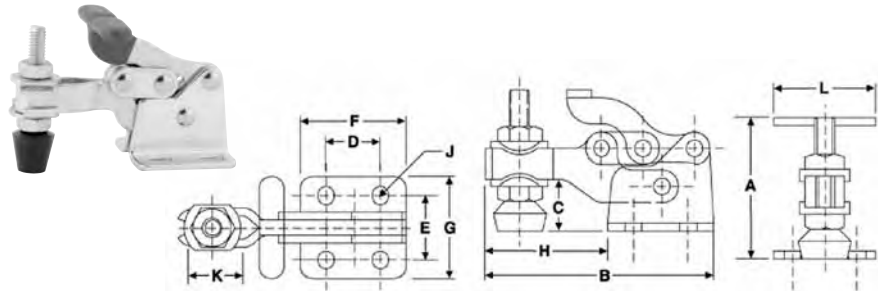

Part No.	A	B	C	D	E	F	G	H	J	K	L	Bar Type	Base Type	Holding Cap. Lbs.	Handle Type
34113	1.47	2.30	0.65	0.53	0.66	1.03	1.03	1.26	0.17	0.44	1.32	ADJUSTABLE BAR	FLANGED	150	STANDARD
34114	2.49	3.68	0.89	0.91	1.17	1.72	1.82	1.93	0.28	0.77	2.01	ADJUSTABLE BAR	FLANGED	350	STANDARD
34115	3.73	5.33	1.31	1.38	1.50	2.52	2.52	2.81	0.31	1.32	2.48	ADJUSTABLE BAR	FLANGED	750	STANDARD

## Horizontal Handle Toggle Clamps Part Number 34120

Bar Opens: 90°  
Handle Opens: 65°  
Spindle Type: Bonded Neoprene  
Spindle Size: 5/16-18 X 3.00

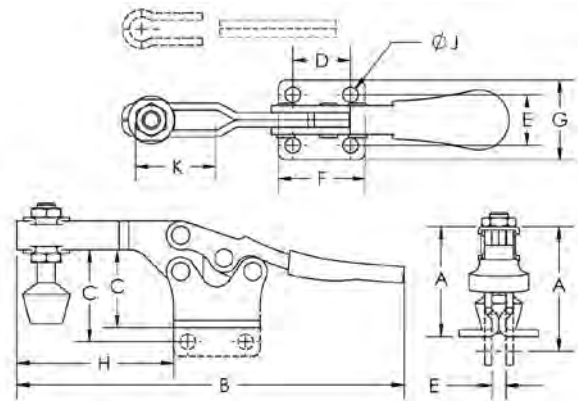

Part No.	A	B	C	D	E	F	G	H	J	K	L	Bar Type	Base Type	Holding Cap. Lbs.	Handle Type
34120	1.96	6.88	1.31	0.99	0.89	1.51	1.36	2.91	0.28	1.31	-	ADJUSTABLE BAR	FLANGED	500	STANDARD

## Horizontal Handle Toggle Clamps Part Number 34130

Bar Opens: 85°  
Handle Opens: 50°  
Spindle Type: Bonded Neoprene  
Spindle Size: 3/8-16 X 3.50

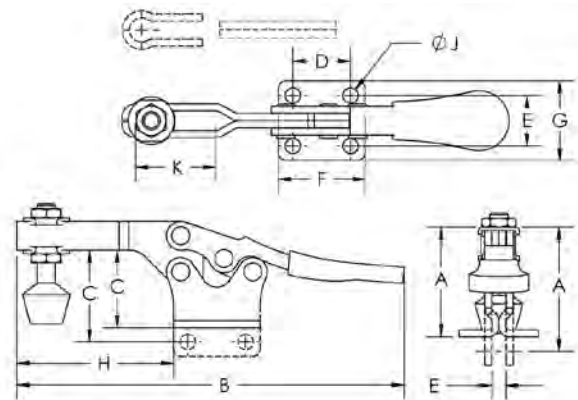

Part No.	A	B	C	D	E	F	G	H	J	K	L	Bar Type	Base Type	Holding Cap. Lbs.	Handle Type
34130	2.55	10.40	1.73	1.62	1.60	2.25	2.23	4.29	0.31	2.74	-	ADJUSTABLE BAR	FLANGED	750	STANDARD

## Straight Line Action Clamps

- Clamps provide push/pull forces
- Tapped plunger allow use of a variety of spindles and attachments
- All clamps supplied with spindle assembly

All TE-CO Toggle Clamps are interchangeable with industry standards

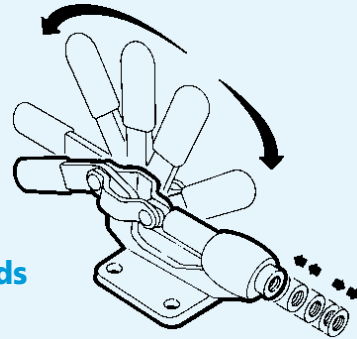

## Straight Line Action Clamps Part Numbers 34300, 34301, 34302

- Spindle Type: Hex Head  
Spindle Size:
- 1/4-20 X .63 (34300)
  - 5/16-18 X 1.00 (34301)
  - 3/8-16 X 1.25 (34302)

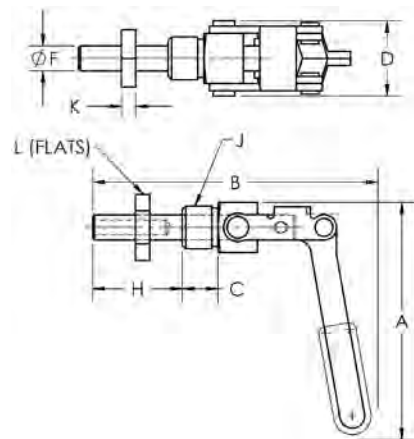

Part No.	A	B	C	D	E	F	G	H	J	K	L	Mounting Type	Handle Type	Holding Cap. Lbs.	Plunger Travel
34300	3.06	2.67	0.48	1.03	-	0.37	-	0.81	0.58	0.26	0.94	THROUGH HOLE	STANDARD	200	.75
34301	4.16	4.26	0.63	1.28	-	0.43	-	1.57	0.73	0.25	1.17	THROUGH HOLE	STANDARD	300	1.50
34302	5.43	6.73	0.88	1.86	-	0.63	-	2.80	1.05	0.35	1.59	THROUGH HOLE	STANDARD	700	2.63

## Straight Line Action Clamps Part Numbers 34305, 34303

- Spindle Type: Hex Head  
Spindle Size:
- #8-32 X .50DP (34305)
  - 1/4-20 X .50LG (34303)

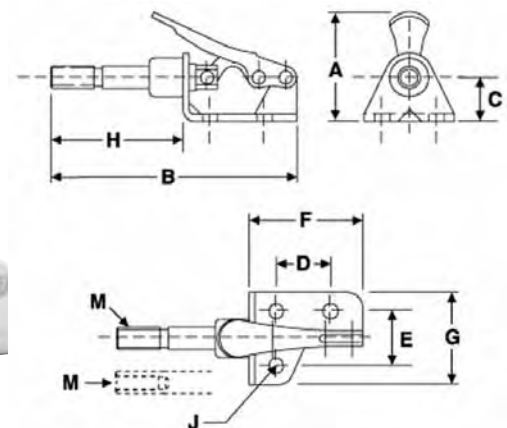

Part No.	A	B	C	D	E	F	G	H	J	M	Mounting Type	Handle Type	Holding Cap. Lbs.	Plunger Travel	Spindle Thread
34303	1.59	2.85	0.57	0.63	0.61	1.32	1.07	1.53	0.17	1/4-20	STANDARD	STANDARD	100	.63	EXTERNAL
34305	1.57	2.67	0.52	0.63	0.61	1.31	1.07	1.35	0.17	0.25	STANDARD	STANDARD	100	.63	INTERNAL

# TOGGLE CLAMPS



## Straight Line Action Clamps Part Number 34306

Spindle Type: Hex Head  
Spindle Size: 5/16-18 X 1.00

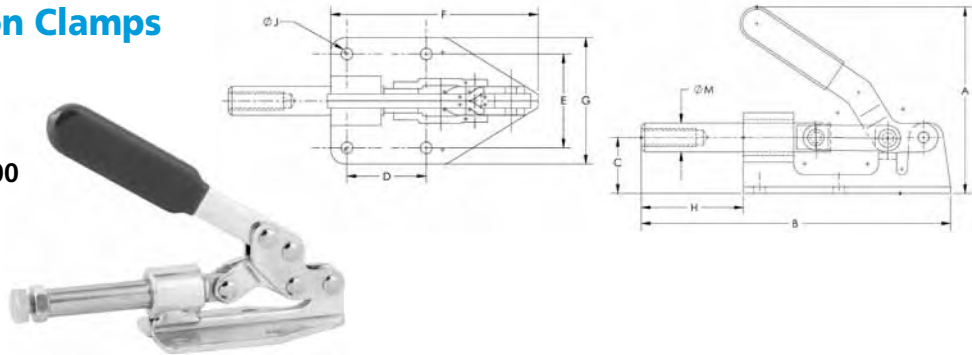

Part No.	A	B	C	D	E	F	G	H	J	M	Mounting Type	Handle Type	Holding Cap. Lbs.	Plunger Travel	Spindle Thread
34306	4.10	5.00	0.85	1.57	1.33	3.27	1.95	1.71	0.26	0.47	FLANGE	STANDARD	300	1.25	INTERNAL

## Straight Line Action Clamps Part Number 34310

Spindle Type: Hex Head  
Spindle Size: 5/16-18 X 1.00

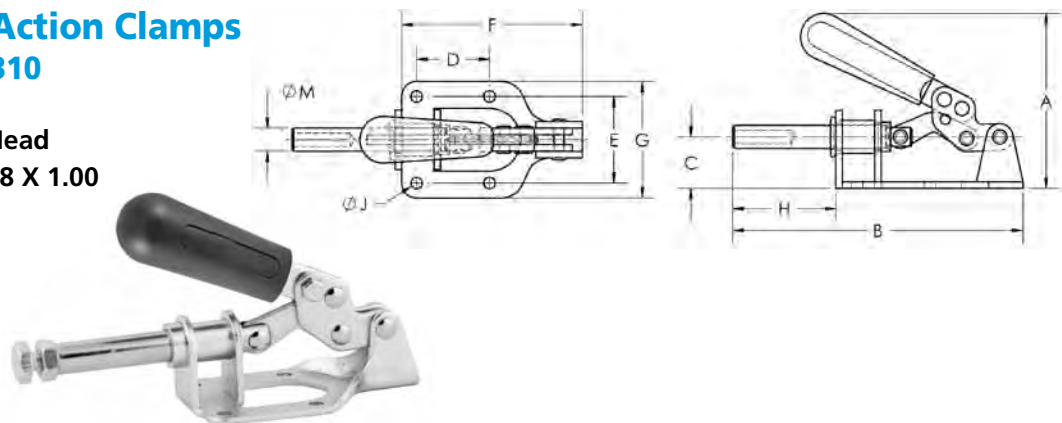

Part No.	A	B	C	D	E	F	G	H	J	M	Mounting Type	Handle Type	Holding Cap. Lbs.	Plunger Travel	Spindle Thread
34310	3.14	5.45	0.98	1.38	1.64	3.55	2.22	1.90	0.22	0.47	FLANGE	STANDARD	300	1.25	INTERNAL

## Straight Line Action Clamps Part Number 34320

Spindle Type: Hex Head  
Spindle Size: 3/8-16 X 1.25

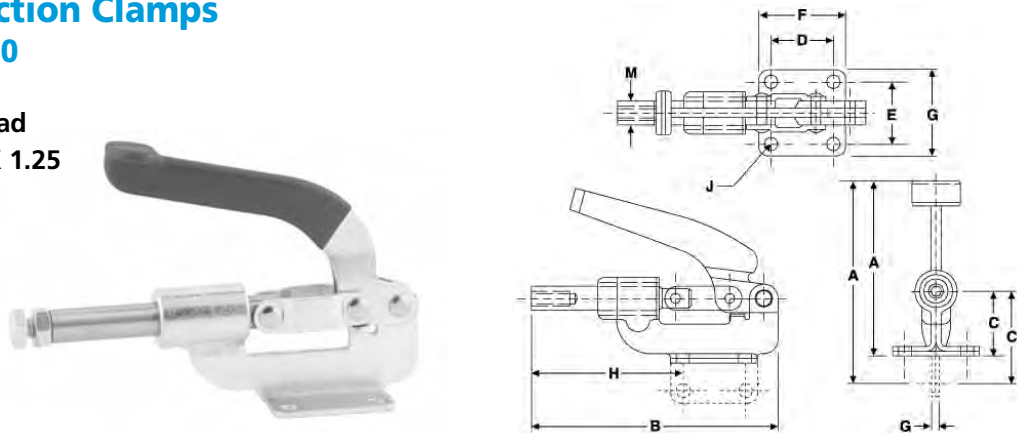

Part No.	A	B	C	D	E	F	G	H	J	M	Mounting Type	Handle Type	Holding Cap. Lbs.	Plunger Travel	Spindle Thread
34320	5.04	6.82	1.75	1.63	1.58	2.25	2.20	4.23	0.34	0.62	FLANGE	STANDARD	800	1.63	INTERNAL



## Straight Line Action Clamps

Part Numbers 34340, 34350,  
34360, 34309, 34308

Spindle Type: Hex Head

Spindle Size:

- 5/16-18 X 1.00 (34340)
- 3/8-16 X 1.25 (34350, 34360)
- 1/2-13 X 2.00 (34309, 34308)

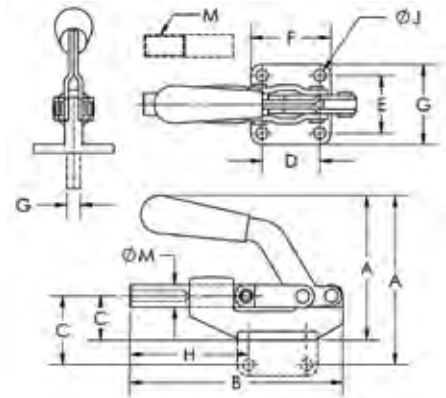

Part No.	A	B	C	D	E	F	G	H	J	M	Mounting Type	Handle Type	Holding Cap. Lbs.	Plunger Travel	Spindle Thread
34340	3.34	3.64	0.98	1.44	1.32	2.30	1.85	2.03	0.23	0.43	FLANGE	45 degrees	600	1.25	INTERNAL
34350	4.19	6.41	1.25	1.62	1.63	2.33	2.25	3.13	0.33	0.63	FLANGE	45 degrees	850	1.65	INTERNAL
34360	4.95	9.39	1.78	1.99	2.00	2.89	2.48	5.00	0.34	0.70	FLANGE	45 degrees	1500	2.36	INTERNAL
34309	4.75	6.41	1.25	1.60	1.62	2.33	2.25	3.14	0.33	0.62	FLANGE	45 degrees	850	1.25	INTERNAL
34308	6.93	9.38	1.83	2.00	2.02	2.85	2.82	5.75	0.35	0.70	FLANGE	45 degrees	1500	2.36	INTERNAL

## Straight Line Action Clamps

Part Numbers 34304, 34330

Spindle Type: Hex Head

Spindle Size:

- 5/16-18 X 1.00 (34304)
- 3/8-16 X 1.25 (34330)

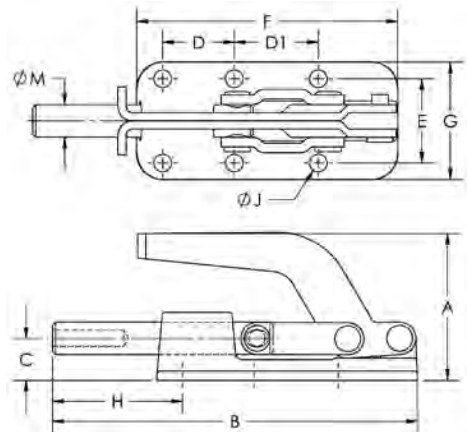

Part No.	A	B	C	D	E	F	G	H	J	M	Mounting Type	Handle Type	Holding Cap. Lbs.	Plunger Travel	Spindle Thread
34304	3.28	6.10	0.68	1.38	1.62	4.30	2.18	1.86	0.28	0.51	FLANGE	STANDARD	800	1.63	INTERNAL
34330	2.93	7.06	0.88	1.39	1.63	5.25	2.24	1.82	0.35	0.63	FLANGE	STANDARD	2500	2.00	INTERNAL

## Pull Action Clamps

Ideal for latching, locking, or fastening doors, fixtures, pressure vessels, covers and hatches on storage tanks

All TE-CO Toggle Clamps are interchangeable with industry standards

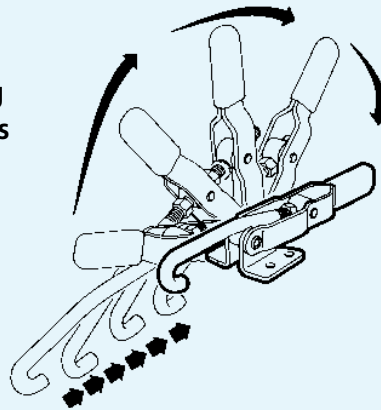

## Pull Action Clamps

Part Numbers 34420, 34425, 34430

Spindle Type: U-Hook • Flanged Base  
Drawing Movement: • Standard Handle

- 1.81" (34420)
- 1.75" (34425)
- 2.50" (34430)

Hook Size:

- M4 (34420)
- M5 (34425)
- M8 (34430)

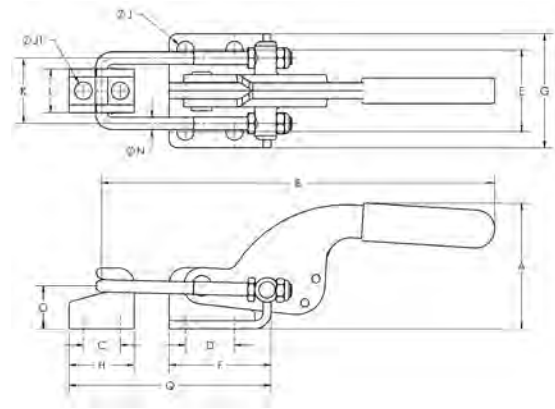

Part No.	A	B	C	D	E	F	G	H	J	K	L	N	O	Q Min	Q Max	Holding Capacity
34420	1.31	4.18	0.40	0.62	0.76	1.03	1.12	0.78	0.17	0.80	0.55	0.13	0.44	1.84	2.57	360
34425	1.91	6.56	0.48	0.78	1.25	1.52	1.75	1.01	0.28	0.79	1.00	0.17	0.50	2.53	3.69	700
34430	2.75	8.48	0.76	1.62	1.44	2.39	2.12	1.17	0.34	1.17	0.31	1.75	0.83	4.39	5.37	2000

## Pull Action Clamps

Part Numbers 34409, 34411

Spindle Type: U-Hook • Flanged Base  
Drawing Movement: • Standard Handle

- 3.50" (34409)
- 2.19" (34411)

Hook Size:

- M10 (34409)
- M12 (34411)

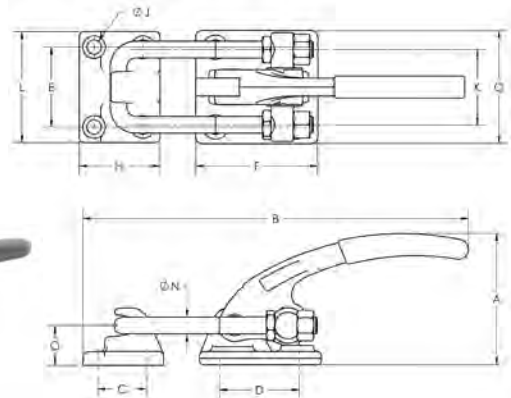

Part No.	A	B	C	D	E	F	G	H	J	K	L	N	O	Q Min	Q Max	Holding Capacity
34409	3.96	11.39	1.37	2.24	2.28	3.43	3.21	2.32	0.41	1.71	3.14	0.39	1.17	6.22	7.21	4000
34411	3.63	10.18	1.37	2.24	2.26	3.43	3.17	2.32	0.41	2.06	3.14	0.46	1.08	6.13	7.25	7500

## Pull Action Clamps

Part Numbers 34404, 34406, 34407

- Spindle Type: U-Hook      • Flanged Base  
 Drawing Movement:      • Standard Handle

- 1.53" (34404)
- 2.00" (34406)
- 2.50" (34407)

Hook Size:

- M4 (34404)
- M6 (34406)
- M8 (34407)

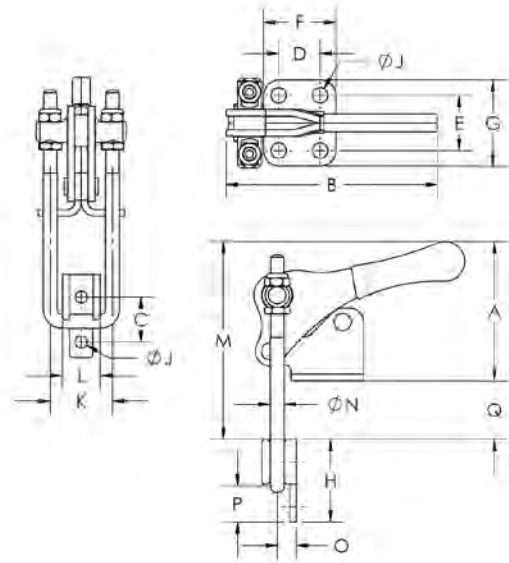

Part No.	A	B	C	D	E	F	G	H	J	K	L	M	N	O	P	Q Min	Q Max	Holding Capacity
34404	2.22	3.15	0.57	0.51	0.87	1.02	1.39	1.00	0.21	0.86	0.54	3.43	0.12	0.20	0.43	0.54	1.20	500
34406	2.86	4.71	0.81	0.75	1.02	1.30	1.56	1.50	0.28	1.06	0.67	4.36	0.23	0.25	0.64	0.54	1.50	1000
34407	3.60	5.25	1.06	1.25	1.47	1.86	2.11	2.13	0.35	1.74	1.19	5.75	0.31	0.50	0.79	2.14	2.11	2000

## Pull Action Clamps

Part Numbers 34401, 34408, 34405

- Spindle Type: U-Hook      • Flanged Base  
 Drawing Movement:      • Standard Handle

- 1.53" (34401)
- 2.00" (34408)
- 2.50" (34405)

Hook Size:

- M4 (34401)
- M6 (34408)
- M8 (34405)

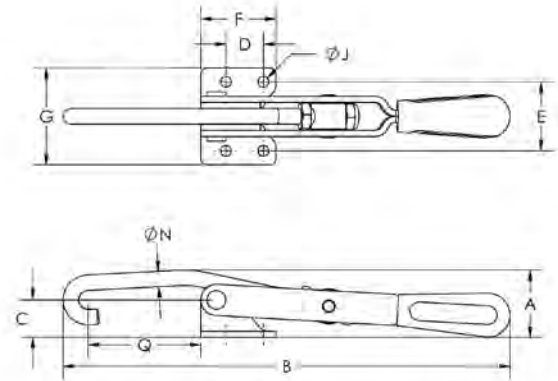

Part No.	A	B	C	D	E	F	G	J	N	Q Min	Q Max	Holding Capacity
34401	1.45	8.33	0.74	0.94	1.44	1.50	1.99	0.24	0.30	1.53	3.11	375
34408	2.17	11.46	0.96	1.25	1.97	1.86	2.61	0.35	0.39	2.70	3.44	750
34405	2.62	13.80	1.82	1.13	2.49	2.13	3.30	0.41	0.47	2.75	3.60	1000

# TOGGLE CLAMPS



## Pull Action Clamps Part Numbers 34403

Drawing Movement: 4.00"

Bar Type: Fixed Hook

Flanged Base

Standard Handle

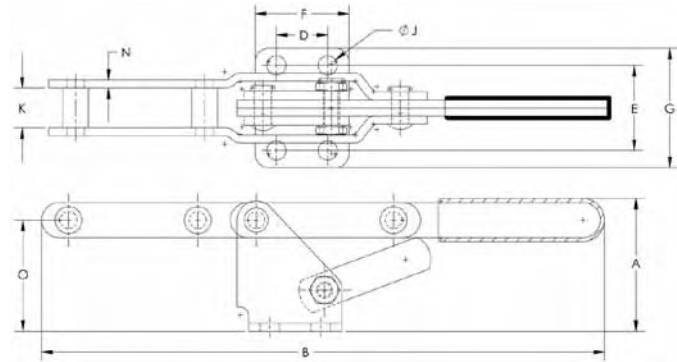

Part No.	A	B	D	E	F	G	J	K	N	O	Holding Capacity
34403	1.88	8.40	0.75	1.22	1.38	1.72	0.28	0.60	0.12	1.59	375

## ACCESSORIES

### Spindle Assemblies

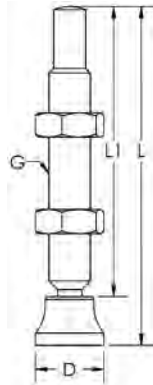

Part No.	D	G	L	L1
34541	0.63	3/8-16	3.62	3.22
34561	0.43	1/4-20	2.72	2.43
34540	0.47	5/16-18	3.48	3.11

### Spindle Assemblies

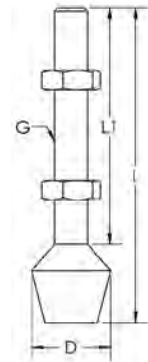

Part No.	D	G	L	L1
34533	0.88	3/8-16	3.44	2.60
34530	0.59	1/4-20	2.17	1.59
34532	0.49	5/16-18	3.05	2.31

### Spindle Assemblies

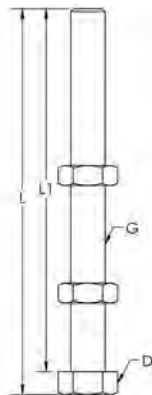

Part No.	D	G	L	L1
34514	0.55	3/8-16	3.23	3.00
34515	0.74	1/2-13	3.31	3.00
34560	0.43	1/4-20	1.65	1.50
34512	0.49	5/16-18	2.71	2.50

### Weldable Bolt Retainers

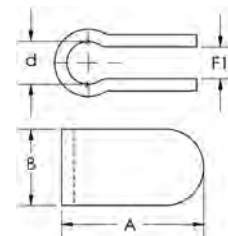

Part No.	A	B	F1	D
34550	1.20	0.64	0.25	0.32
34551	1.47	0.74	0.33	0.41
34552	1.70	1.19	0.38	0.67